

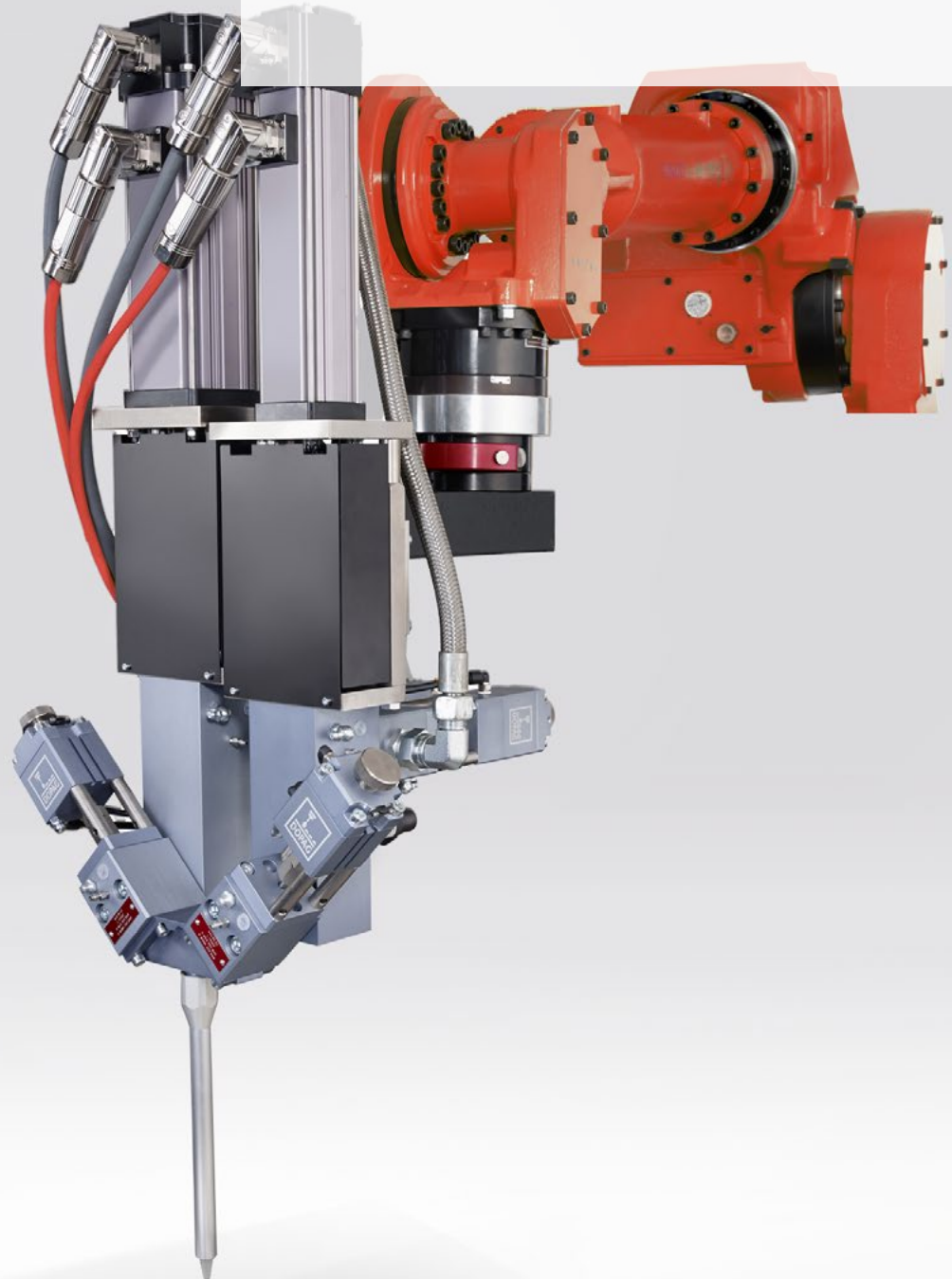

METER · MIX · DISPENSE

vectodis vectomix

FOR THE PROCESSING OF LOW
TO HIGH VISCOSITY MATERIALS



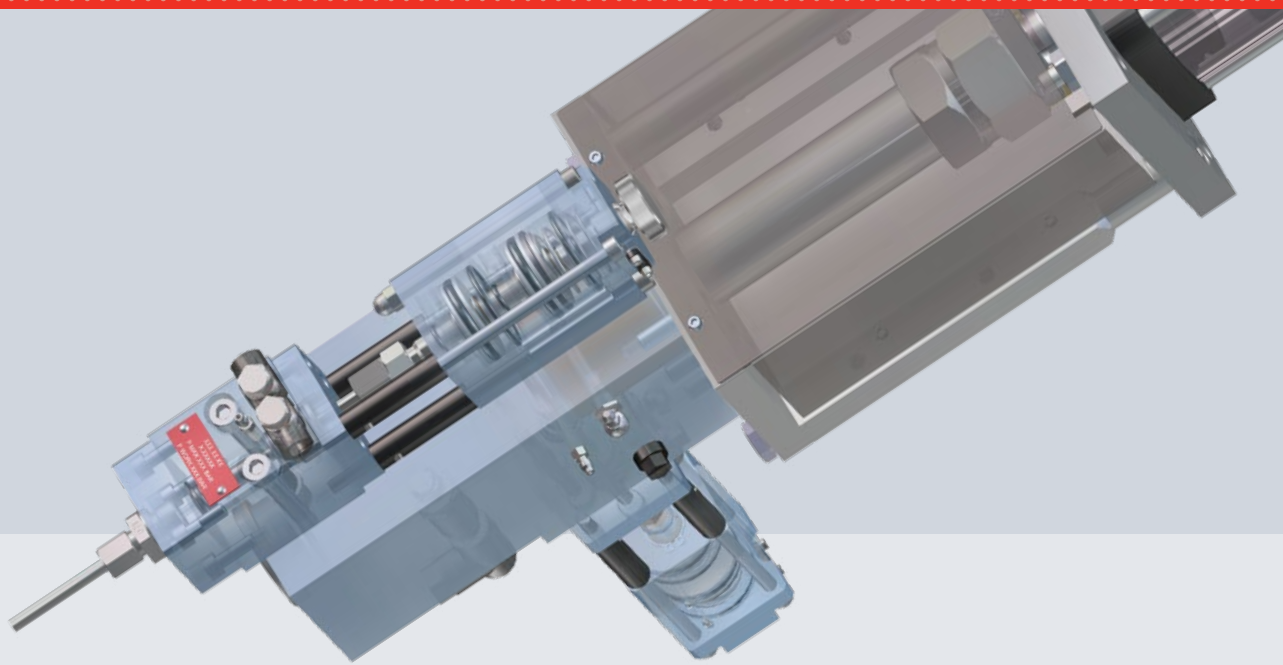

vectodis ^

Application areas

.....

- Bonding
- Sealing
- Moulding
- Encapsulation
- Shot dispensing
- Bead dispensing

Features and benefits

.....

- Modular construction enables a wide range of use, variable mixing ratios and flow rates
- High precision through metering and mixing at the point of application
- High process security through:
 - construction with reduced dead space
 - de-airing on the top of the metering chamber
 - metering chamber with pressure monitoring
- Optimization of the maintenance through:
 - specially guided metering pistons
 - coupling between drive and metering piston
 - hermetic sealing of the piston with additional sealing liquid

Industries

.....

These modern metering systems can be used in any industry where materials need to be applied in a high precision and repeatable way.

- Automotive
- Electrical and electronic
- Renewable energy
- Aerospace
- White goods
- and many more

Control unit

.....

To control these systems a metering computer with touch screen terminal is used.

With this metering computer all applications that can be achieved with vectodis or vectomix can be parameterised and different metering processes can be memorised.

The control unit is wired into a control cabinet. The metering computer can also handle applications where a speed proportional material supply is required, for example in combination with a robot.

Maximum Perfection

To process low to high viscosity and even abrasive materials, DOPAG has developed two product lines, vectodis and vectomix.

These products are the result of consistent research, development and engineering with the goal of finding a visionary concept, able to set standards for the future in metering technology. The modular construction of vectodis and vectomix enables a wide range of use.

Whenever the process requires a highly dynamic and precise application, these two products are used. Both systems can be configured for weight-optimized automation with a flexible hose connection between the feeder and the application system.

The rotational movement of a servo motor is converted into a linear movement by means of a spindle which is driving the steel piston. Various constructional characteristics are resulting in minimal maintenance and reduced service intervals which leads to a longer product life.

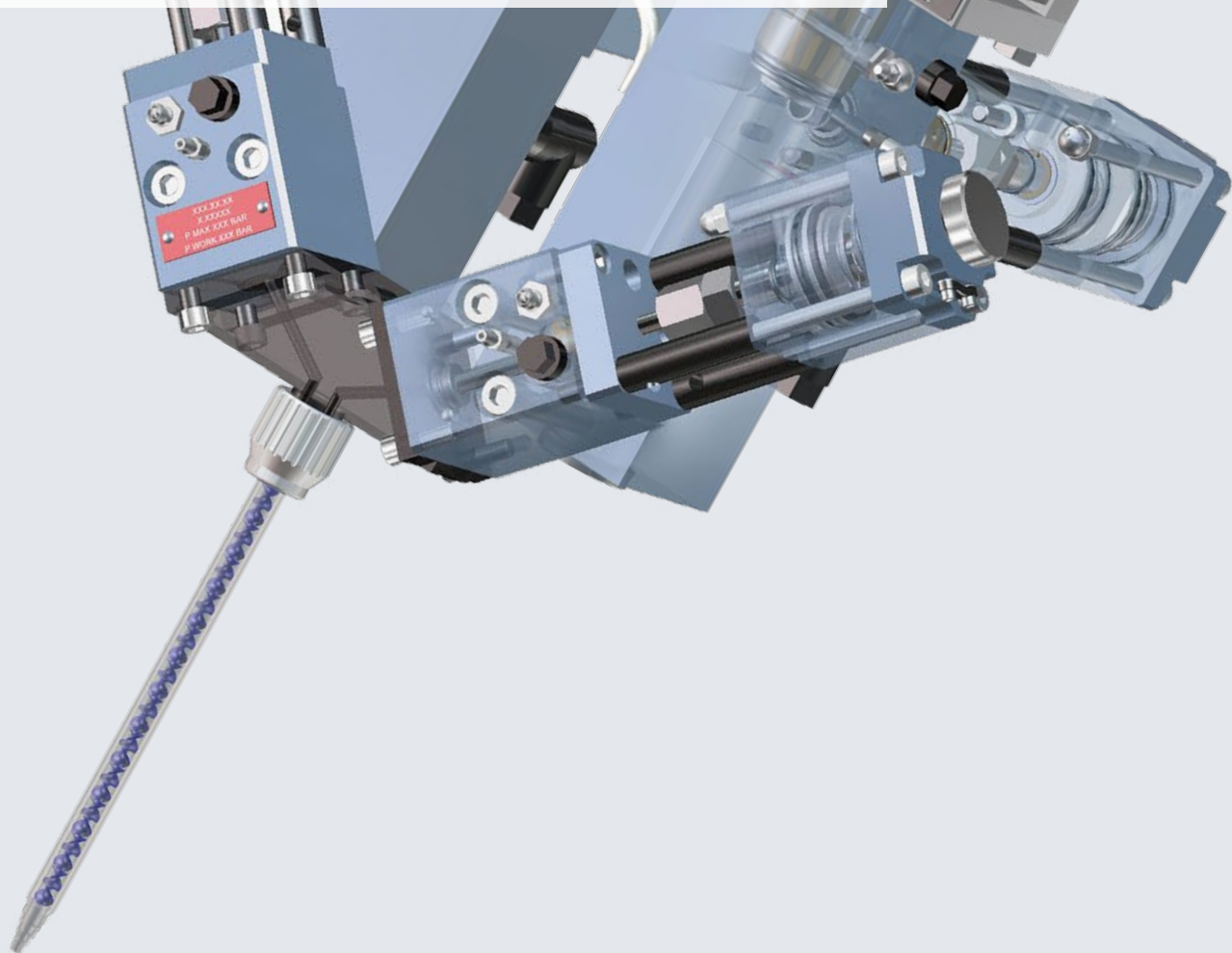

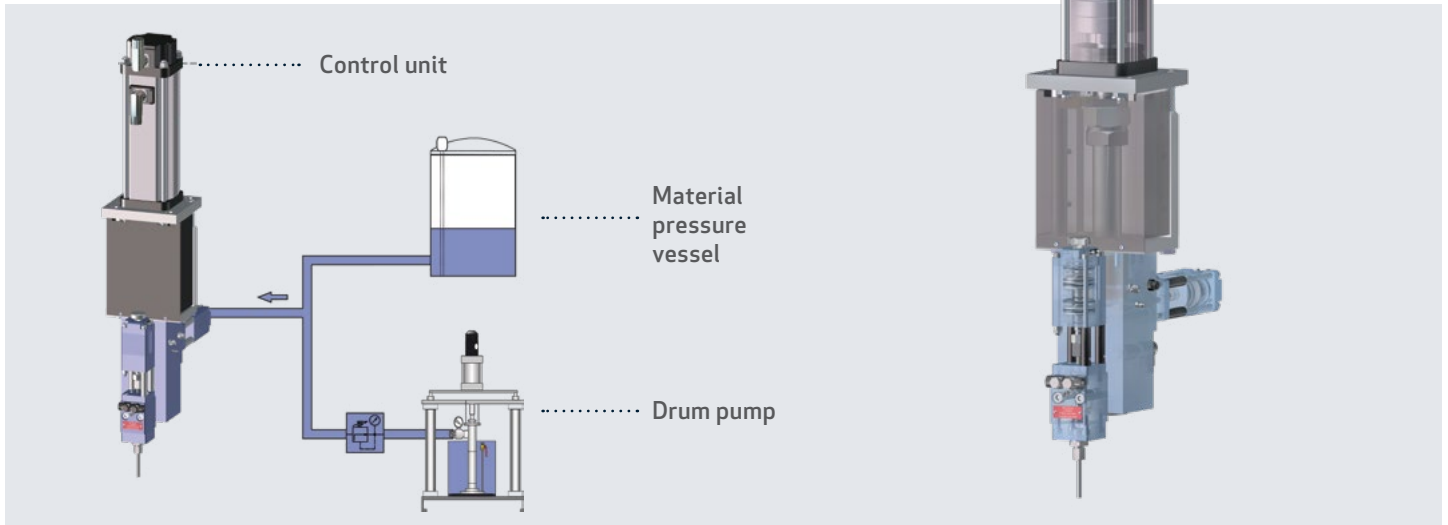

The vectodis metering system is suitable for processing single-component media. The material is discharged in shot or bead form. The material is taken from the original container via a feed pump and fed to a piston metering unit with a servo motor. A material pressure regulator keeps the input pressure at the piston metering unit constant.

The material is discharged via a dispensing valve located at the outlet of the piston metering unit. The metering control unit

enables communication between the individual system components and coordinates the various features of the metering components. It can be operated conveniently via a touch panel. All the relevant process data is displayed here. The metering control unit enables features such as speed-proportional metering, which allows vectodis to be combined with an industrial robot. The software also provides modern features such as pre-compression and leakage control for reliable, reproducible application over the long term.

Size	ø 6	ø 10	ø 20	ø 36
Max. metering volume	1.8 ml	7.8 ml	31 ml	101 ml
Min. metering volume (5 mm stroke)	0.14 ml	0.4 ml	1.6 ml	5.1 ml
Metering stroke	65 mm	100 mm	100 mm	100 mm
Max. flow rate*	2.75 ml/s	7.8 ml/s	31 ml/s	101 ml/s
Min. metering time (Full stroke)*	0.65 s	1.0 s	1.0 s	1.0 s
Min. cycle time (Full stroke)*	2.5 s	3.0 s	3.0 s	3.0 s
Max. supply pressure	160 bar	160 bar	100 bar	100 bar
Min. supply pressure	3 bar	3 bar	3 bar	3 bar
Max. working pressure	160 bar	160 bar	100 bar	100 bar
Viscosity range**	50 –1,000,000 mPas	50 –1,000,000 mPas	50 –1,000,000 mPas	50 –1,000,000 mPas
Power supply	400 VAC 3/N/PE / 50/60 Hz 230 VAC L/N/PE / 50/60 Hz 220-240 VAC 3/PE / 50/60 Hz	400 VAC 3/N/PE / 50/60 Hz 230 VAC L/N/PE / 50/60 Hz 220-240 VAC 3/PE / 50/60 Hz	400 VAC 3/N/PE / 50/60 Hz 230 VAC L/N/PE / 50/60 Hz 220-240 VAC 3/PE / 50/60 Hz	400 VAC 3/N/PE / 50/60 Hz 230 VAC L/N/PE / 50/60 Hz 220-240 VAC 3/PE / 50/60 Hz
Max. dimensions	102 x 320 x 596 mm	116 x 365 x 759 mm	116 x 365 x 769 mm	150 x 390 x 858 mm
Weight	approx. 9.3 kg	approx. 11.8 kg	approx. 14.9 kg	approx. 26.9 kg

* Depending on material characteristic, material supply pressure and use of the material compression function

** Other on request

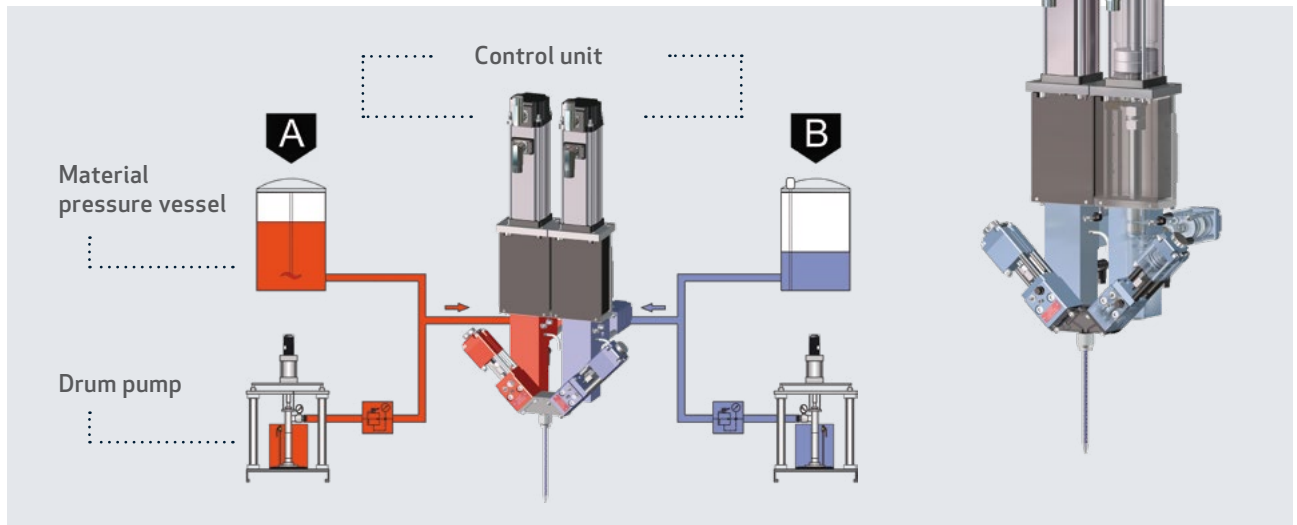

The vectomix is used to handle multi component materials. Due to its compatibility and modularity, two vectodis single component piston metering systems with equal or different sizes are used. They can be connected by simply using a mixing block onto the outlet of which a

disposable plastic mixer is mounted. The use of a hose package with a decentralized mixing system is also possible. Just a suitable material supply and metering computer is required.

Size	ø 6/6	ø 10/10	ø 20/20	ø 36/36
Max. metering volume**	3.6 ml	15.6 ml	62 ml	202 ml
Min. metering volume ** (5 mm stroke)	0.3 ml	0.8 ml	3.2 ml	10.2 ml
Metering stroke	65 mm	100 mm	100 mm	100 mm
Max. flow rate*	5.5 ml/s	15.6 ml/s	62 ml/s	202 ml/s
Mixing ratio*	100:100 bis 100:5 ***	100:100 bis 100:5 ***	100:100 bis 100:5 ***	100:100 bis 100:5 ***
Min. metering time (Full stroke)*	0.65 s	1.0 s	1.0 s	1.0 s
Min. cycle time (Full stroke)*	2.5 s	3.0 s	3.0 s	3.0 s
Max. supply pressure	160 bar	160 bar	100 bar	100 bar
Min. supply pressure	3 bar	3 bar	3 bar	3 bar
Max. working pressure	160 bar	160 bar	100 bar	100 bar
Viscosity range****	50-1,000,000 mPas	50-1,000,000 mPas	50-1,000,000 mPas	50-1,000,000 mPas
Power supply	400 VAC 3/N/PE /50/60 Hz 230 VACL/N/PE /50/60 Hz 220-240 VAC 3/PE /50/60 Hz	400 VAC 3/N/PE /50/60 Hz 230 VACL/N/PE /50/60 Hz 220-240 VAC 3/PE /50/60 Hz	400 VAC 3/N/PE /50/60 Hz 230 VACL/N/PE /50/60 Hz 220-240 VAC 3/PE /50/60 Hz	400 VAC 3/N/PE /50/60 Hz 230 VACL/N/PE /50/60 Hz 220-240 VAC 3/PE /50/60 Hz
Max. dimensions	415 x 350 x 544 mm	415 x 365 x 709 mm	415 x 365 x 719 mm	449 x 390 x 825 mm
Weight	approx. 19.3 kg	approx. 24.3 kg	approx. 30.3 kg	approx. 55.3 kg

* Depending on material characteristic, material supply pressure and use of the material compression function

** For volumetric mixing ratio 1:1 | *** Lower on request | **** Other on request



We are one of the world's most experienced manufacturers of high-quality metering technology. Wherever adhesives, resins, silicones or lubricants are metered and applied in industrial production, we offer reliable, precise solutions. We provide systems and components for highly automated production processes, including for the automotive, wind, household appliances and electrical industries, as well as for aviation.

DOPAG is part of the HILGER & KERN GROUP, a reliable supplier and a development and service partner to industrial companies in a variety of market segments for more than 90 years. The group employs around 350 people and has subsidiaries and distributors in more than 40 countries.



Global sales and service network

Find your local DOPAG contact



DOPAG China

Shanghai
+86 21 3368 7775
office@dopag.cn
www.dopag.cn

DOPAG Eastern Europe

Prague
+420 777 762 161
info@dopagcz.com
www.dopagcz.com

DOPAG France

Valence
+33 4 75419060
contact@dopag.fr
www.dopag.fr

DOPAG Germany

Hilger und Kern, Mannheim
+49 621 3705-500
info@dopag.de
www.dopag.de

DOPAG UK

Droitwich
+44 1299 250740
uksales@dopag.com
www.dopag.co.uk

DOPAG India

Bangalore
+91 8750 979 979
sales@dopag.in
www.dopag.in

DOPAG Italy

Alpignano (Turin)
+39 011 9348888
info@dopag.it
www.dopag.it

DOPAG Mexico

Saltillo, Coahuila
+52 844 430 9934
sales@dopag.mx
www.dopag.mx

DOPAG Korea

Seoul
+82 31 213-3705
info@dopag.co.kr
www.dopag.co.kr

DOPAG Switzerland

Cham
+41 41 7855 757
info@dopag.ch
www.dopag.ch

DOPAG USA

Erlanger, Kentucky
+1 859 918 5690
ussales@dopag.com
www.dopag.us

We're present in more than 40 countries. Find your local sales partner here:
www.dopag.com/contacts

